

Epoxy resin free-flow grouts conforming to the requirements of BS EN1504-3 Class R4 and BS EN 1504-6 Anchoring of reinforcing steel bar.

Uses

For grouting under baseplates, crane rails, turbines where heavy dynamic loads are encountered and areas where chemical spillage may occur.

Typical applications include:

- Reciprocating machinery
- Testing equipment
- Heavy crane and transporter rails
- High speed turbines
- Centrifuges
- Drop forges
- Electroplating and chemical plants
- Anchoring of steel bars

Advantages

- Low creep characteristics under sustained loading
- Resistant to repetitive dynamic loads
- Non-shrink, ensuring complete surface contact and bond
- High compressive, tensile and flexural strengths
- Fast, convenient installation with rapid strength gain
- Withstands a wide range of chemicals
- Two grades available for gap widths 0.25 - 10 mm and 10 - 120 mm

Description

Conbextra EP are epoxy resin based products designed for free-flow grouting of gap thicknesses from 0.25 to 120 mm. Two grades of product are available:

Conbextra EP10 for grouting gap thicknesses from 0.25 to 10 mm. Comprising of a two component, low viscosity unfilled epoxy resin system which is mixed and poured into the gap.

Conbextra EPR for grouting gap thicknesses from 10 to 120 mm. A three-component system consisting of base resin, liquid hardener and specially graded inert fillers, which are mixed and poured into the gap.

Specification Clause

The epoxy grout shall be Conbextra EP, a multi-component resin grout conforming to the requirements of BSEN 1504-3 Class R4 and BSEN 1504-4. For gaps between 0.25 and 10 mm Conbextra EP10 should be used and for gaps between 10 and 120 mm Conbextra EPR should be used.

Conbextra EPR: The hardened grout shall have a compressive strength in excess of 95 MPa at 7 days and a flexural strength in excess of 37 MPa at 7 days.

Conbextra EP10: The hardened grout shall have a compressive strength in excess of 95 MPa at 7 days and a flexural strength in excess of 80 MPa at 7 days.

The storage handling and placement of the grout shall be in strict accordance with the manufacturer's instructions.

Standard Compliance

Conbextra EP10 and Conbextra EPR complies with the classification R4 according to BS EN 1504-3.

Conbextra EP10 and Conbextra EPR complies with the requirements of BS EN 1504 -6: Anchoring of reinforced steel

CE	
Fosroc Ltd, Drayton Manor Business Park, Coleshill Road, Tamworth, Staffs, B78 3TL 09 0370-CPD-0845	
EN 1504-3; EN 1504-6 Concrete repair products for structural repair PC mortar. Anchoring of reinforced steel bar	
Compressive strength	Class R4 (≥ 45 MPa)
Chloride ion content	≤ 0.05 %
Adhesive bond strength	≥ 2.0 MPa
Determination of shrinkage and expansion	≥ 2.0 MPa
Carbonation resistance	$d_k \leq$ control concrete
Reaction to fire	Class C1 s1 d0
Testing of anchoring products by pull out method	@ 75 KN load ≤ 0.6 mm
Glass transition temperature	$>45^\circ\text{C}$ or 20°C above max ambient temperature
Determination of creep under sustained load	Displacement < 0.6 mm @ 3 months
Dangerous substances	Complies with 5.4 (1504-3) Complies with 5.3 (1504-6)

Fosroc® Conbextra EP

Properties

The following results were obtained at a temperature of 20°C unless otherwise stated.

Test method	Standard	EN 1504 Requirement	Test result		
			Conbextra EP10		Conbextra EPR
Compressive Strength	EN 2190:1999	Class R4 \geq 45 MPa	- MPa - MPa 100MPa	@ 1 Day @ 3 Day @ 7 Day	90 MPa - MPa 100 MPa
Bond strength by pull off:	EN 1542:1999	Class R4 \geq 2.0 MPa	3.2 MPa		2.9 MPa
Chloride ion content:	EN 1015-17:2000	Class R4 \leq 0.05 %	0.00 %		0.00 %
Determination of shrinkage and expansion:	EN 12617-4:2002	Class R4 > 2MPa	3.1 MPa 3.1 MPa	Shrinkage Expansion MPa	2.9 MPa 2.8 MPa
Elastic modulus in compression	EN 13412:2002	Class R4 \geq 20 GPa	-		22 GPa
Testing of anchoring products by pull out method	EN 1881:2006	@ 75 KN load \leq 0.6 mm	0.45 mm 0.51 mm	Dry test Wet test	0.30 mm 0.38 mm
Determination of creep under sustained load	EN 1544:2007	Displacement 0.6 mm @ 3 months	0.36 mm		0.43 mm
Glass transition temperature	EN 12614:2006	> 45 or 20°C above max ambient temperature	51°C		56°C
Fire rating	EN 13501-1	-	Class C1 s1 dO		
Flexural strength	BS 6319 Pt 3:1990	-	81 MPa		37 MPa
Flexural modulus	BS 6319 Pt 3 1990	-	3.6 GPa		15.5 GPa
Tensile strength	BS 6319 Pt 3:1985	-	29 MPa		14 MPa
Pot life	-		40 min 20 min 10 min	@ 10°C @ 20°C @ 30°C	60 min 30min 15 min
Minimum thickness	-		0.25 mm		10 mm
Maximum thickness	-		10 mm		120 mm

Clarification of property values: The typical properties given above are derived from laboratory testing. Results derived from field applied samples may vary.

Flow characteristics

The maximum distance of flow is governed by the gap thickness, the head of grout applied and the ambient temperature. The following table gives typical data for flow design.

	Temperature °C	Gap thickness(mm)	Hydrostatic head (mm)	Maximum flow (mm)
EPR:	5	12	100	450
	5	35	100	900
	20	12	100	900
	20	35	100	2000

EP10: Flow determined by gap thickness and pressure applied

Fosroc® Conbextra EP

Application instructions

Preparation

Foundation surface

All contact surfaces must be free from oil, grease, free-standing water or any loosely adherent material. Concrete surfaces should be cut back to a sound base either by a grit blast or light scabble. All dust must be removed and bolt holes or fixing pockets blown clean of any dirt or debris.

Steel surfaces

All steel surfaces should be shot blasted to SA2.5, free of rust and mill scale. Cleaned surfaces may be protected by the application of Nitoprime 28.

Formwork

The formwork should be constructed to be leakproof as Conbextra EP products are free-flowing grouts. Loss of grout once the material is placed but not hardened, will result in incomplete filling of the gap.

For free-flow grout conditions it is essential to provide a hydrostatic head of grout. To achieve this a feeding hopper system should be used.

Example of Conbextra EP grout to individual rail baseplate:

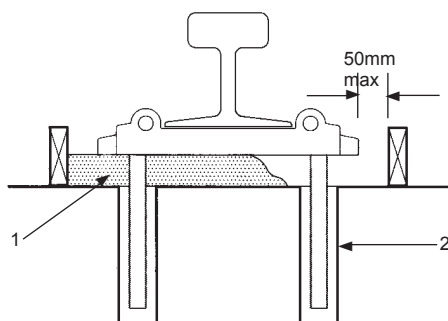

Example of Conbextra EP grout to machinery baseplate:

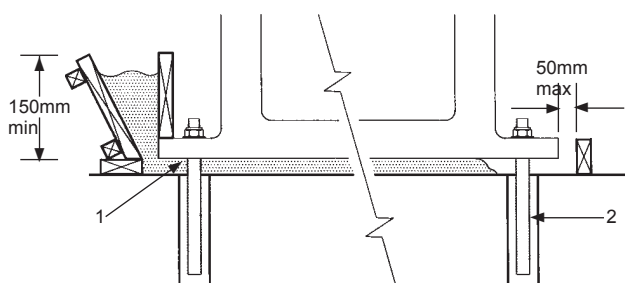

1 Conbextra EP grout

2 *Lokfix resin anchor

* Also available from Fosroc.

Mixing

Pour all the contents of the hardener pack into the base container. Mix using a slow speed power drill and paddle until homogeneous.

Conbextra EPR: Pour all the resultant liquid into a container with a capacity of 15 to 25 litres. Add all the filler provided. Mix using a slow speed power drill and paddle for 2 minutes or until a uniform colour is achieved in the grout.

Placing

The mixed grout should be poured steadily from one side only to eliminate the entrapment of air.

Continuous grout flow is essential.

Sufficient grout must be available prior to starting.

The time taken to pour a batch should be regulated to the time taken to prepare the next batch.

After curing the unrestrained grout should be cut back below the bottom of the baseplate using a skill saw.

Cleaning

All tools and equipment should be cleaned immediately after use with Fosroc Solvent 102. Spillages should be absorbed with sand or sawdust and disposed in accordance with local regulations.

Estimating

Supply

EP10: 3 litre packs, containing liquid base and hardener. 2 x 1.5 litre units

EPR: 8 and 16 litre packs, containing base, hardener and filler

Fosroc Solvent 102: 5 and 25 litre containers

Limitations

Temperature

During application:

For both products grouting may be carried out without special precautions at ambient temperatures from 5°C to 25°C. Where temperatures exceed 20°C note the pot life will be reduced.

Cure temperatures below 15°C will result in slower strength build up; at 5 °C cure will stop until the material warms.

Exotherm: All epoxy systems will develop a temperature rise on mixing. Its extent will be a function of the volume to surface ratio, the ambient temperature as well as the mass and thermal conductivity of the surrounding materials. Mixed Conbextra EP10 will in quantities above approximately 200 grams exotherm producing vapour. Ensure good ventilation and do not breath fumes. Contact Fosroc Technical Services for specific advice.

Fosroc® Conbextra EP

In service:

The cured grouts, which are completely resistant to frost and sub-zero temperatures, are suitable for use up to 45°C. Contact Fosroc Technical Services for advice.

Storage

Conbextra EP products have a shelf life of 12 months if kept in dry conditions at 20°C.

Precautions

Health and safety

For further information refer to appropriate Product Safety Data Sheet available at www.fosroc.com

Fire

Fosroc Solvent 102 is flammable. In the event of fire extinguish with CO₂ or foam.

Flash point

Fosroc Solvent 102:	33°C
---------------------	------



Important note

Fosroc products are guaranteed against defective materials and manufacture and are sold subject to its standard Conditions for the Supply of Goods and Services, copies of which may be obtained on request. Whilst Fosroc endeavours to ensure that any advice, recommendation, specification of information it may give is accurate and correct, it cannot, because it has no direct or continuous control over where or how its products are applied, accept any liability either directly or indirectly arising from the use of its products, whether or not in accordance with any advice, specification, recommendation of information given by it.

Fosroc Limited

Drayton Manor Business Park
Coleshill Road, Tamworth,
Staffordshire B78 3TL. UK

www.fosroc.com

telephone:
+44 0 (1827) 262222

fax:
+44 0 (1827) 262444

email:
enquiryuk@fosroc.com



Certificate number FM 610